

1.25Gbps SFP Transceiver

Features

- ◆ Operating data rate up to 1.25Gbps
- ◆ 850nm VCSEL Laser Transmitter
- ◆ 550m with 50/125 μ m MMF, 300m on 62.5/125 μ m MMF
- ◆ Single 3.3V Power supply and TTL Logic Interface
- ◆ Duplex LC Connector Interface
- ◆ Hot Pluggable
- ◆ Operating Case Temperature
Standard: 0 $^{\circ}$ C ~ +70 $^{\circ}$ C ,
Industrial: -40 $^{\circ}$ C ~ +85 $^{\circ}$ C
- ◆ Compliant with MSA SFP Specification
- ◆ Digital diagnostic monitor interface
Compatible with SFF-8472

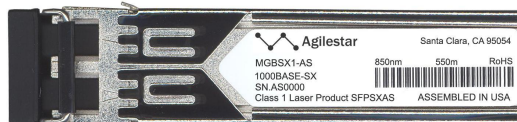

Applications

- ◆ Gigabit Ethernet
- ◆ Fiber channel
- ◆ Switch to switch interface
- ◆ High speed I/O for file servers

Product Description

The MGBSX1-AS multi-mode transceiver is a small form factor pluggable module for bi-directional serial optical data communications such as Gigabit Ethernet 1000BASE-SX and Fiber Channel FC-PH-2 for 100-M5-SN-1 and 100-M6-SN-1. It is with the SFP 20-pin connector to allow hot plug capability. This module is designed for multi-mode fiber and operates at a nominal wavelength of 850 nm.

The transmitter section uses a Vertical Cavity Surface Emitted Laser (VCSEL) and is Class 1 Laser compliant according to International Safety Standard IEC 60825. The receiver section uses an integrated GaAs detector preamplifier (IDP) mounted in an optical header and a limiting post-amplifier IC.

The MGBSX1-AS is designed to be compliant with SFF-8472 SFP Multi-source Agreement (MSA).

Regulatory Compliance

Feature	Standard	Performance
Electrostatic Discharge (ESD) to the Electrical Pins	MIL-STD-883E Method 3015.7	Class 1(>500 V) Isolation with the case
Electromagnetic Interference (EMI)	FCC Part 15 Class B	Compatible with standards
Laser Eye Safety	FDA 21CFR 1040.10 and 1040.11 EN60950, EN (IEC) 60825-1,2	Compatible with Class I laser product. Compatible with T _ü V standards
Component Recognition	UL and CUL	UL file E317337
Green Products	RoHS	RoHS6

Absolute Maximum Ratings

Parameter	Symbol	Min.	Max.	Unit
Storage Temperature	T _S	-40	+85	°C
Supply Voltage	V _{CC}	-0.5	3.6	V

Recommended Operating Conditions

Parameter	Symbol	Min.	Typical	Max.	Unit
Operating Case Temperature	T _A	MGBSX1-AS	0	+70	°C
		MGBSX1-AS-I	-40	+85	
Power Supply Voltage	V _{CC}	3.15	3.3	3.45	V
Power Supply Current	I _{CC}			300	mA
Surge Current	I _{Surge}			+30	mA
Baud Rate			1.25		GBaud

PERFORMANCE SPECIFICATIONS - ELECTRICAL

Parameter	Symbol	Min.	Typ.	Max	Unit	Notes
TRANSMITTER						
LVPECL Inputs(Differential)	V _{in}	400		2500	mVp	AC coupled inputs
Input Impedance (Differential)	Z _{in}	85	100	115	ohms	R _{in} > 100 kohms @ DC
Tx_DISABLE Input Voltage - High		2		3.45	V	
Tx_DISABLE Input Voltage - Low		0		0.8	V	



Tx_FAULT Output Voltage -- High		2		V _{cc} +0.3	V	I _o = 400μA; Host V _{cc}
Tx_FAULT Output Voltage -- Low		0		0.5	V	I _o = -4.0mA
RECEIVER						
LVPECL Outputs (Differential)	V _{out}	400	800	1200	mV _{pp}	AC coupled outputs
Output Impedance (Differential)	Z _{out}	85	100	115	ohms	
Rx_LOS Output Voltage - High		2		V _{cc} +0.3	V	I _o = 400μA; Host V _{cc}
Rx_LOS Output Voltage - Low		0		0.8	V	I _o = -4.0mA
MOD_DEF (0:2)	VoH	2.5			V	With Serial ID
	VoL	0		0.5	V	

Optical and Electrical Characteristics

Parameter	Symbol	Min.	Typical	Max.	Unit
50μm Core Diameter MMF	L			550	m
Data Rate			1.25		Gbps
Transmitter					
Centre Wavelength	λ _c	820	850	860	nm
Spectral Width (RMS)	σ			0.85	nm
Average Output Power	P _{out}	-9		-4	dBm
Extinction Ratio	EX	9			dB
Rise/Fall Time(20% ~80%)	tr/tf			260	ps
Output Optical Eye	ITU-T G.957 Compliant				
Data Input Swing Differential	V _{IN}	500		2000	mV
Input Differential Impedance	Z _{IN}	90	100	110	Ω
TX Disable	Disable		2.0	V _{cc} +0.3	V
	Enable		0	0.8	
TX_Fault	Fault		2.0	V _{cc} +0.3	V
	Normal		0	0.8	
TX_Disable Assert Time	t _{off}			10	us
Receiver					
Centre Wavelength	λ _c	760		860	nm
Receiver Sensitivity	P _{IN}			-17	dBm
Output Differential Impedance	P _{IN}	90	100	110	Ω
Data Output Swing Differential	V _{OUT}	370		2000	mV
Rise/Fall Time	Tr/tf			2.2	ns

LOS De-Assert		LOS _D			-20	dBm
LOS Assert		LOS _A	-40			dBm
LOS	High		2.0		V _{CC} +0.3	V
	Low		0		0.8	

SFP Transceiver Electrical Pad Layout

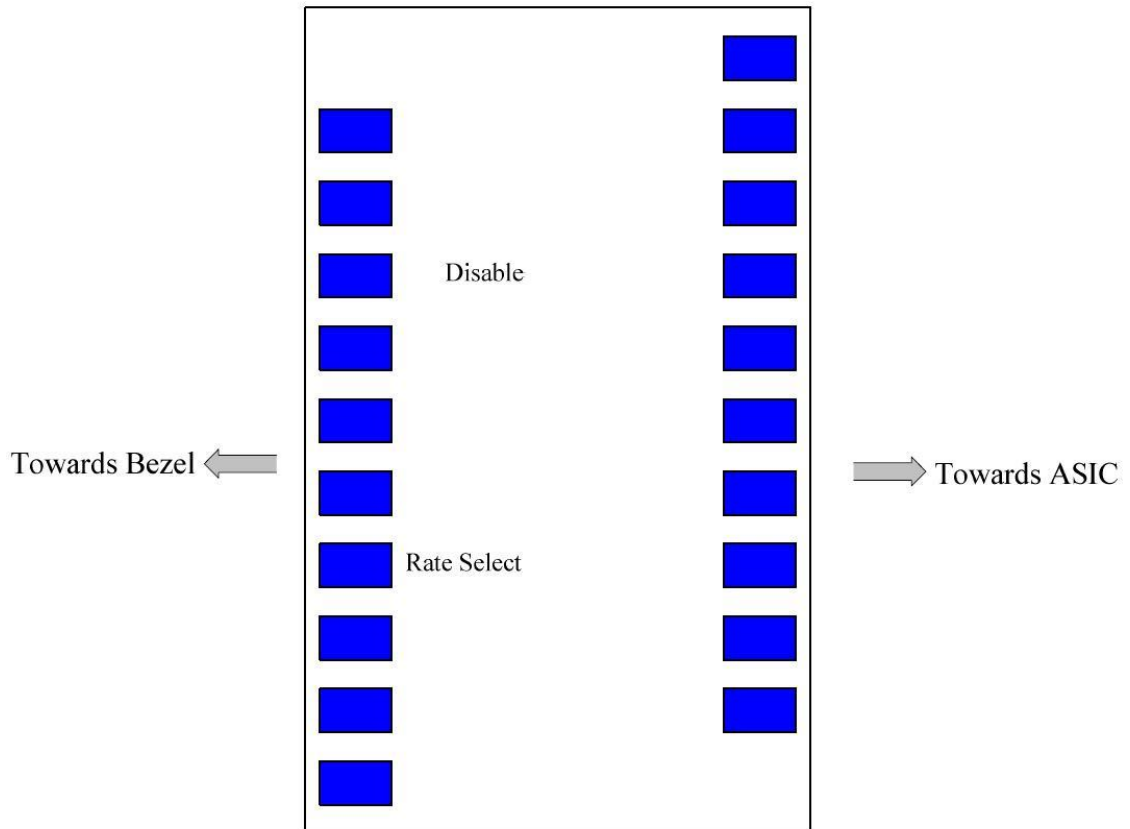

Pin Function Definitions

Pin Num.	Name	FUNCTION	Plug Seq.	Notes
1	VeeT	Transmitter Ground	1	
2	TX Fault	Transmitter Fault Indication	3	Note 1
3	TX Disable	Transmitter Disable	3	Note 2, Module disables on high or open
4	MOD-DEF2	Module Definition 2	3	Note 3, Data line for Serial ID.
5	MOD-DEF1	Module Definition 1	3	Note 3, Clock line for Serial ID.

6	MOD-DEF0	Module Definition 0	3	Note 3, Grounded within the module.
7	Rate Select	Not Connect	3	Function not available
8	LOS	Loss of Signal	3	Note 4
9	VeeR	Receiver Ground	1	Note 5
10	VeeR	Receiver Ground	1	Note 5
11	VeeR	Receiver Ground	1	Note 5
12	RD-	Inv. Received Data Out	3	Note 6
13	RD+	Received Data Out	3	Note 7
14	VeeR	Receiver Ground	1	Note 5
15	VccR	Receiver Power	2	$3.3 \pm 5\%$, Note 7
16	VccT	Transmitter Power	2	$3.3 \pm 5\%$, Note 7
17	VeeT	Transmitter Ground	1	Note 5
18	TD+	Transmit Data In	3	Note 8
19	TD-	Inv. Transmit Data In	3	Note 8
20	VeeT	Transmitter Ground	1	Note 5

Notes:

1) TX Fault is an open collector/drain output, which should be pulled up with a 4.7K – 10K Ω resistor on the host board. Pull up voltage between 2.0V and VccT, R+0.3V. When high, output indicates a laser fault of some kind. Low indicates normal operation. In the low state, the output will be pulled to < 0.8V.

2) TX disable is an input that is used to shut down the transmitter optical output. It is pulled up within the module with a 4.7 – 10 K Ω resistor. Its states are:

Low (0 – 0.8V): Transmitter on

(>0.8, < 2.0V): Undefined

High (2.0 – 3.465V): Transmitter Disabled

Open: Transmitter Disabled

3) Mod-Def 0,1,2. These are the module definition pins. They should be pulled up with a 4.7K – 10K Ω resistor on the host board. The pull-up voltage shall be VccT or VccR (see Section IV for further details). Mod-Def 0 is grounded by the module to indicate that the module is present Mod-Def 1 is the clock line of two wire serial interface for serial ID Mod-Def 2 is the data line of two wire serial interface for serial ID

4) LOS (Loss of Signal) is an open collector/drain output, which should be pulled up with a 4.7K – 10K Ω resistor. Pull up voltage between 2.0V and VccT, R+0.3V. When high, this output indicates the received optical power is below the worst-case receiver sensitivity (as defined by the standard in use). Low indicates normal operation. In the low state, the output will be pulled to < 0.8V.

5) VeeR and VeeT may be internally connected within the SFP module.

6) RD-/+: These are the differential receiver outputs. They are AC coupled 100 Ω differential lines which should be terminated with 100 Ω (differential) at the user SERDES. The AC coupling is done inside the module and is thus not required on the host board. The voltage swing on these lines will be between 370 and 2000 mV differential (185 –1000 mV single ended) when properly terminated.

7) VccR and VccT are the receiver and transmitter power supplies. They are defined as 3.3V \pm 5% at the SFP connector pin. Maximum supply current is 300mA. Recommended host board power supply filtering is shown below. Inductors with DC resistance of less than 1 ohm should be used in order to maintain the required voltage at the SFP input pin with 3.3V supply voltage. When the recommended supply-filtering network is used, hot plugging of the SFP transceiver module will result in an inrush current of no more than 30mA greater than the steady state value. VccR and VccT may be internally connected within the SFP transceiver module.

8) TD-/+: These are the differential transmitter inputs. They are AC-coupled, differential lines with 100 Ω differential termination inside the module. The AC coupling is done inside the module and is thus not required on the host board. The inputs will accept differential swings of 500 – 2400 mV (250 – 1200mV single-ended), though it is recommended that values between 500 and 1200 mV differential (250 – 600mV single-ended) be used for best EMI performance.

EEPROM

The serial interface uses the 2-wire serial CMOS EEPROM protocol defined for the ATMEL AT24C02/04 family of components. When the serial protocol is activated, the host generates the serial clock signal (SCL). The positive edge clocks data into those segments of the EEPROM that are not write protected within the SFP transceiver. The negative edge clocks data from the SFP transceiver. The serial data signal (SDA) is bi-directional for serial data transfer. The host uses SDA in conjunction with SCL to mark the start and end of serial protocol activation. The memories are organized as a series of 8-bit data words that can be addressed individually or sequentially.

The Module provides diagnostic information about the present operating conditions. The transceiver generates this diagnostic data by digitization of internal analog signals. Calibration and alarm/warning threshold data is written during device manufacture. Received power monitoring, transmitted power monitoring, bias current monitoring, supply voltage monitoring and temperature monitoring all are implemented. The diagnostic data are raw A/D values and must be converted to real world units using calibration constants stored in EEPROM locations 56 – 95 at wire serial bus address A2h. The digital diagnostic memory map specific data field define as following .For detail EEPROM information, please refer to the related document of SFF 8472 Rev 9.3

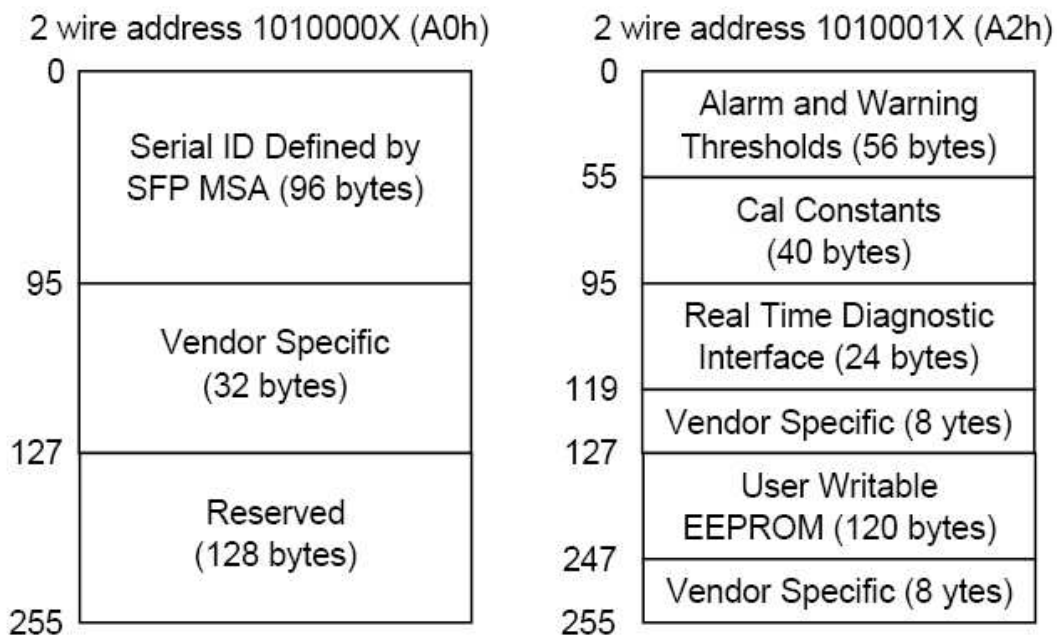

Recommend Circuit Schematic

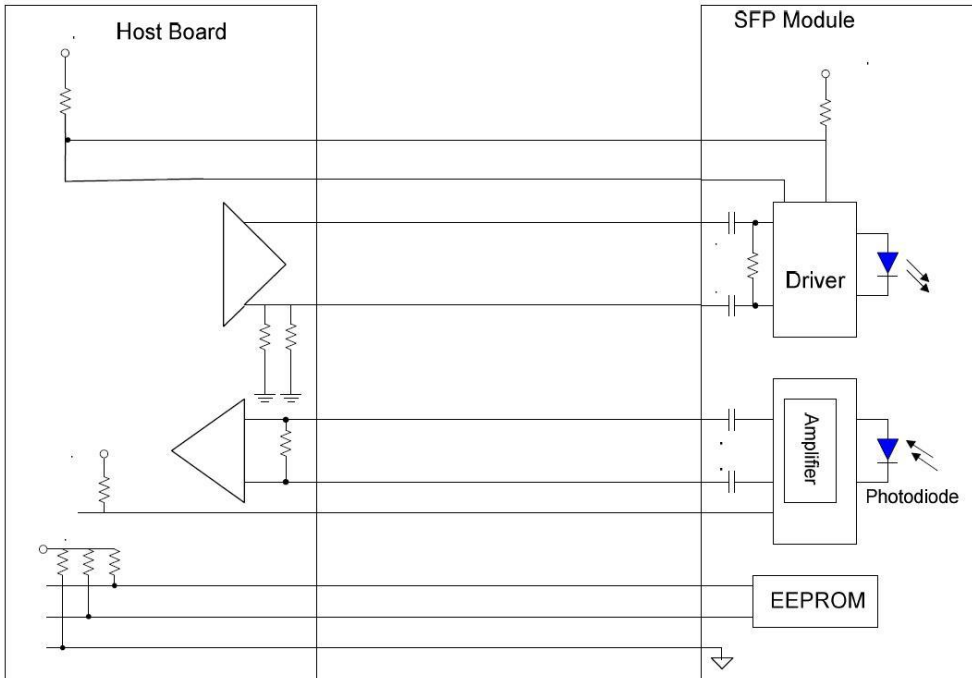

Mechanical Specifications

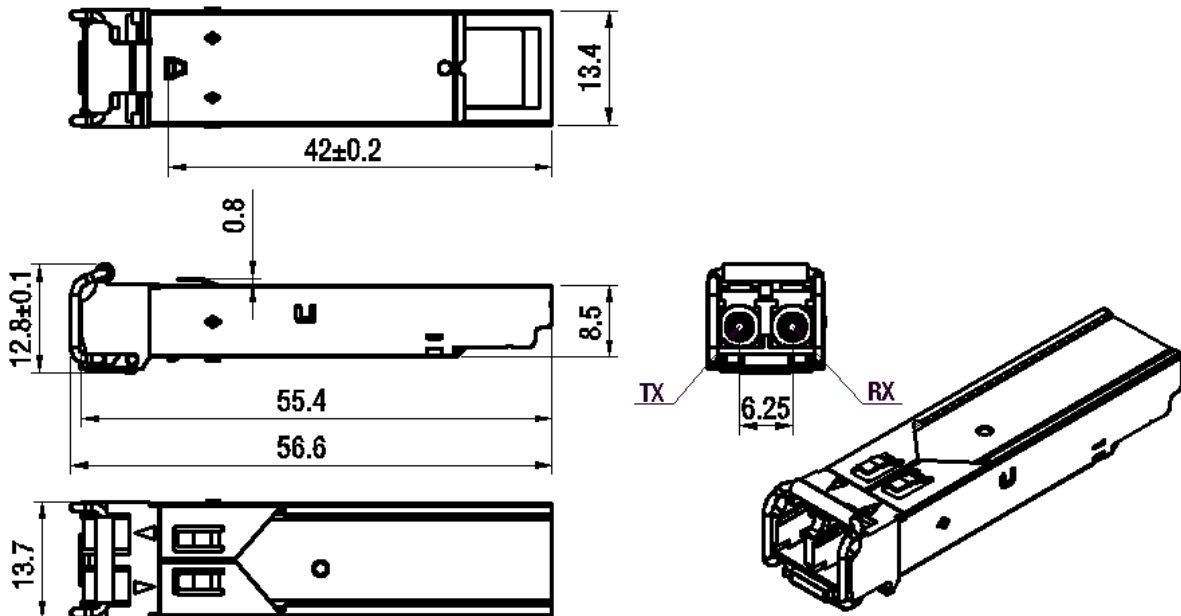



Ordering information

Part No.	Data Rate	Laser	Fibre Type	Distance	Optical Interface
MGBSX1-AS	1.25Gbps	850nm VCSEL	MMF	550m	LC

NOTICE:

Agilestar reserves the right to make changes to or discontinue any optical link product or service identified in this publication, without notice, in order to improve design and/or performance.

CONTACT:

Tel: 1-408-855-8418

Fax: 1-408-486-5653

E-mail: sales@agilestar.com

<http://www.agilestar.com>